

IGBT COLD PLATE

IGBT's cold plate and internal water channel use skived fin process to produce micro water channel structure, which is welded by friction stir welding process, it has very efficient heat dissipation performance. CNC precision machining of overall dimensions can meet the heat dissipation requirements of IGBT with different sizes and powers. Designed to fit standard IGBT and other power electronics applications. we can also customize any of the cold plate sizes to fit into your application



PRODUCT SPECIFICATIONS

- Plates Details: Extruded Aluminum 6063-T5
- Skived process to make the Micro water channel
- Friction stir welding process
- Standard Finish: Chromate Coating
- High thermal Conductivity
- 1/4 NPT threaded input and output
- Low pressure drop
- Superior heat transfer
- Measurement : 162*147*20mm,1.5kg

IGBT COMPATIBILITY

- Semikron SemiX® 3
- Infineon EconoDUAL™3
- Fuji Semiconductor Spring Contact Module
- Powered NX™ Series
- Other IGBTs or high power devices

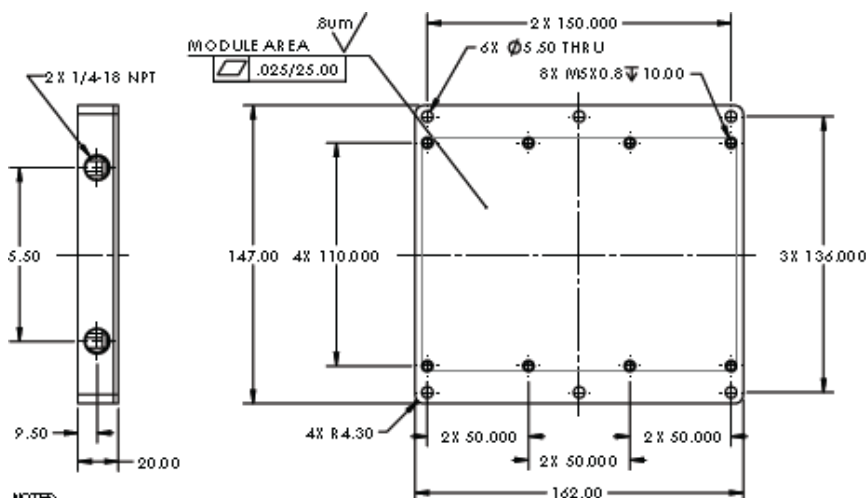

- NOTES:
1. DIMENSIONS ARE IN MM.
 2. TOLERANCES: X.XX ± 0.25 MM, X.XXX ± 0.125 MM.
 3. THIRD ANGLE PROJECTION.

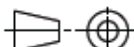

THERMAL SIMULATION ANALYSIS

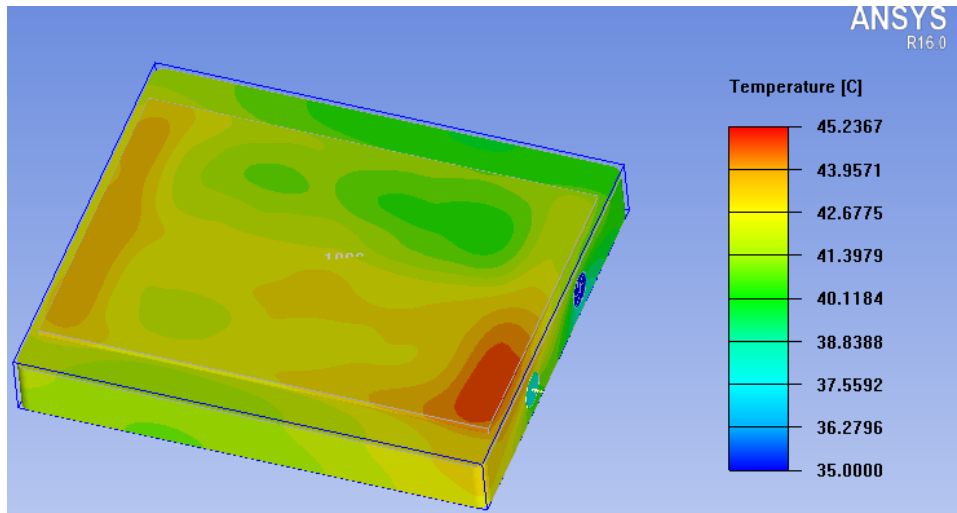

- Thermal power @ 1000W
- The ambient temperature is 35 ° C
- The flow of water 4LPM
- Thermal resistance: $(45.2-35)/500=0.0102$

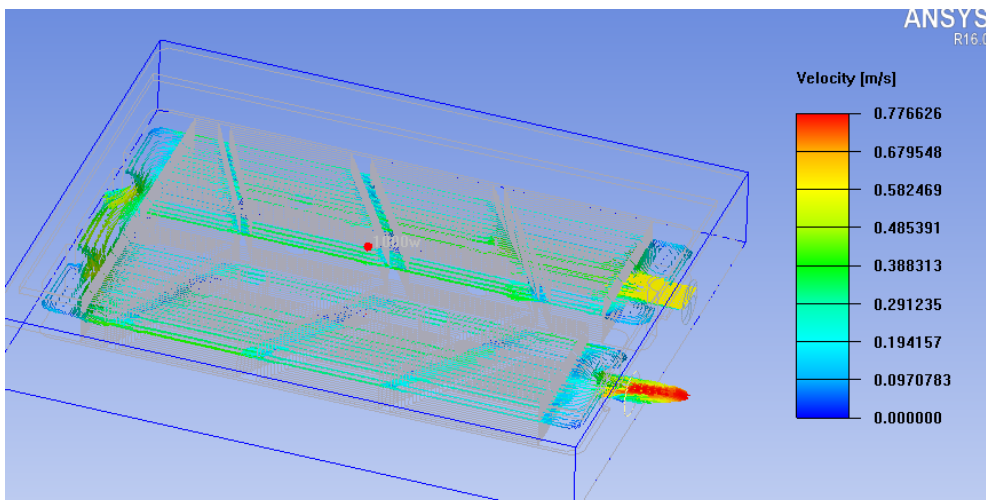

- Velocity Max 0.74m/s

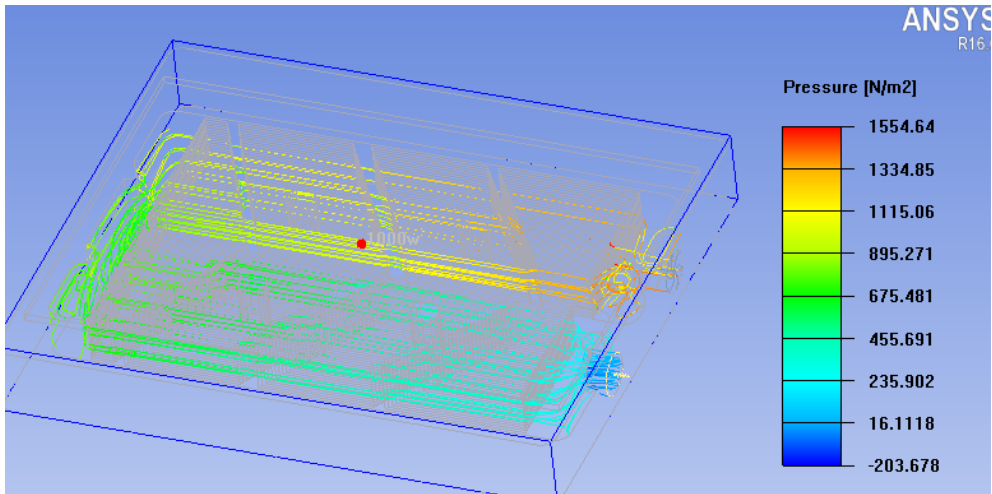

- Pressure Max 1554N/m²